

ROTATING ANTI SCALE BARRIERS

Product Specification Sheet

Highly effective rotating barrier system comprising of 300mm diameter

Aluminium preformed spikes fitted to centre tubing that allows them to rotate.

The system is secured using preformed galvanised steel brackets, which can be fitted to the top of existing fences, walls, buildings and boundaries.

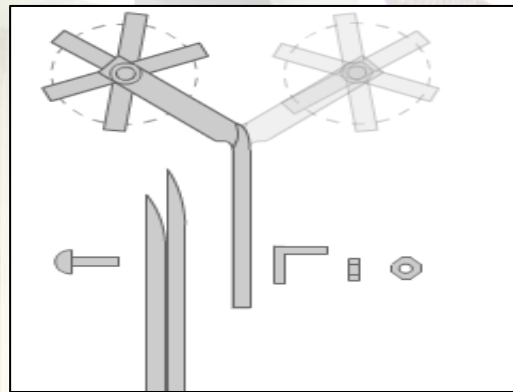

Anti-Scale barriers are fitted to the highest of standards to insurance company recommendations. They are proven as one of the most effective deterrents that provide a cost effective and ideal way to secure your premises. They can be fitted to most applications, giving you peace of mind by deterring thieves and unwanted trespassers.

If you need any further help or advice, please contact us.



www.tss-security.com

E. sales@tss-security.com

T. 0115 9794902

F. 0115 9794575

